



# INSTALLATION INSTRUCTIONS

Accessory

FOG LIGHTS

Application

2008 RIDGELINE

Publications No.

All 36765

Issue Date

JUN 2007

## PARTS LIST

Fog Light Kit  
P/N 08V31-SJC-100

Right fog light

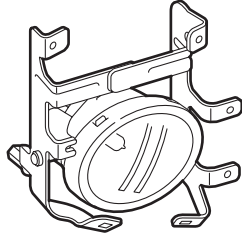

Left fog light

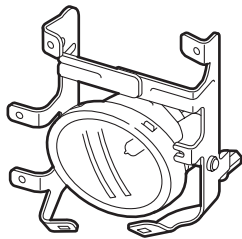

Right trim

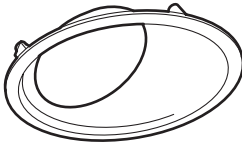

Left trim

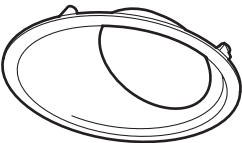

Fog light harness

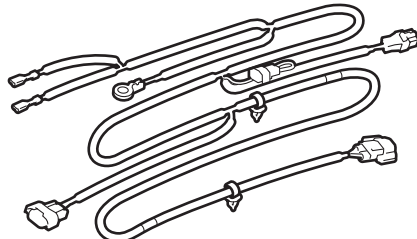

Switch harness

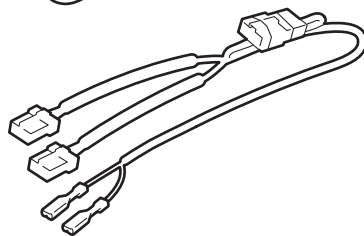

20A Fuse block



Relay

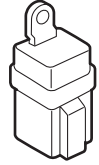

15 Wire ties

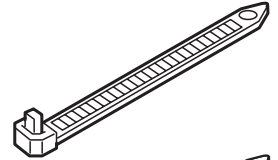

2 Wire ties with clips  
(black)

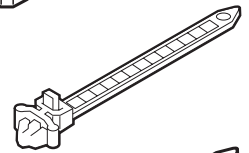

5 Wire ties with clips  
(white)

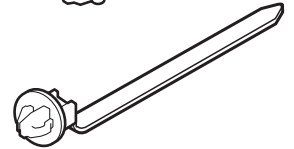

Relay bracket

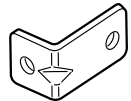

2 Washer-bolts, 6 x 12 mm

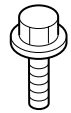

2 Flange nuts, 6 mm



10 Self-tapping screws, 5 x 16 mm

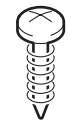

4 Screw grommets



4 Self-tapping screws, 5 x 12 mm  
(black)



Fuse label

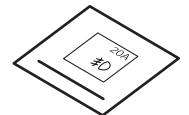

Ground bolt



Small wire ties

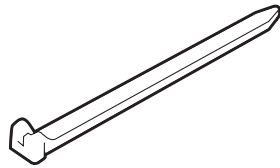

Switch Kit (sold separately)

P/N 08V31-SJC-120A (NH-574L, Warm Gray)  
08V31-SJC-130A (NH607L, Dark Gray)

Fog light switch

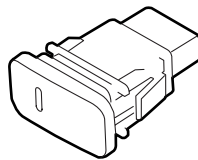

## TOOL AND SUPPLIES REQUIRED

#2 Phillips screwdriver  
Flat-tip screwdriver  
10 mm Combination wrench  
10 mm Socket  
Ratchet  
File  
Eye protection (face shield, safety goggles, etc.)  
Diagonal cutters  
Utility knife  
Pushpin  
Drill  
Shop towel  
Hacksaw blade  
3 mm and 5 mm Drill bits  
40 mm Hole saw  
Blanket

## Illustration of the Fog Lights Installed on the Vehicle

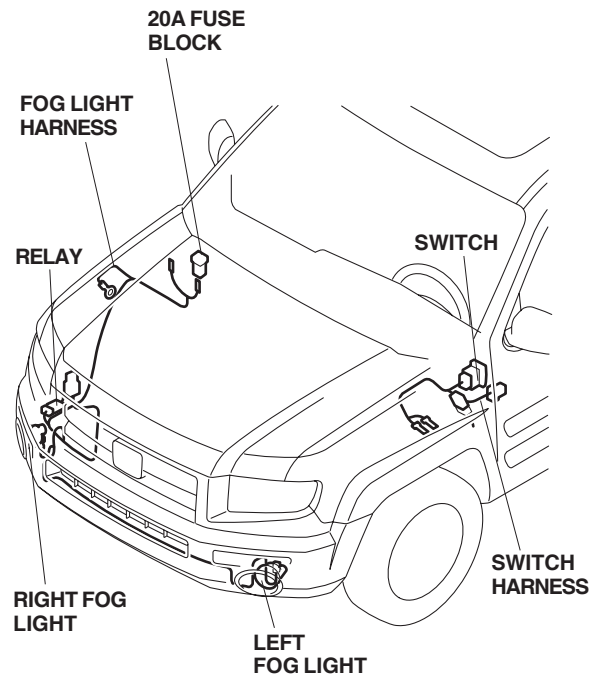

## INSTALLATION

**Customer Information:** The information in this installation instruction is intended for use only by skilled technicians who have the proper tools, equipment, and training to correctly and safely add equipment to your vehicle. These procedures should not be attempted by “do-it-yourselfers.”

1. Make sure you have the anti-theft code for the radio, then write down the radio station presets.
2. Disconnect the negative cable from the battery.

## Cutting the Front Bumper

3. Remove the front bumper.
  - Remove the seven clips along the top of the front bumper and radiator cover.
  - Remove the two clips, six bolts and two self-tapping screws, and remove the front bumper.
  - Place the front bumper on a blanket.

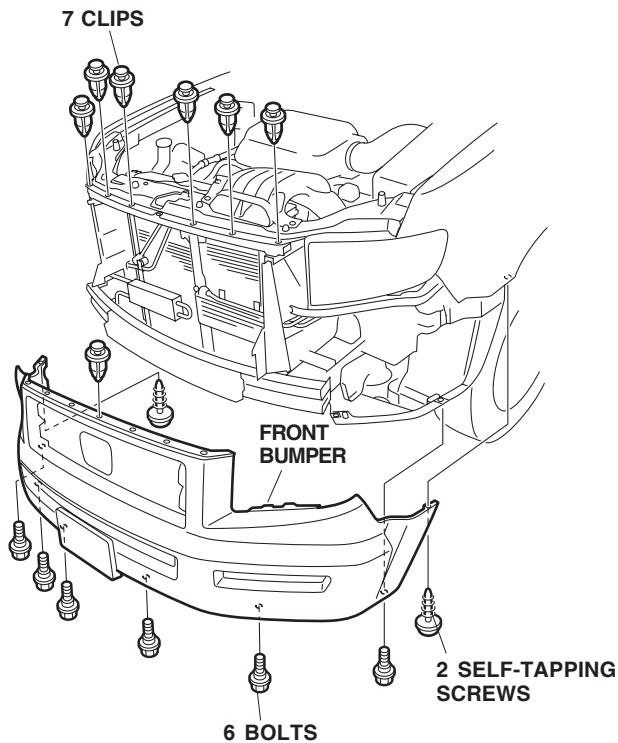

4. On the inside of the front bumper, locate the fog light identification marks on the left side. Using a pushpin, mark the front bumper at each of the eight marks as shown.

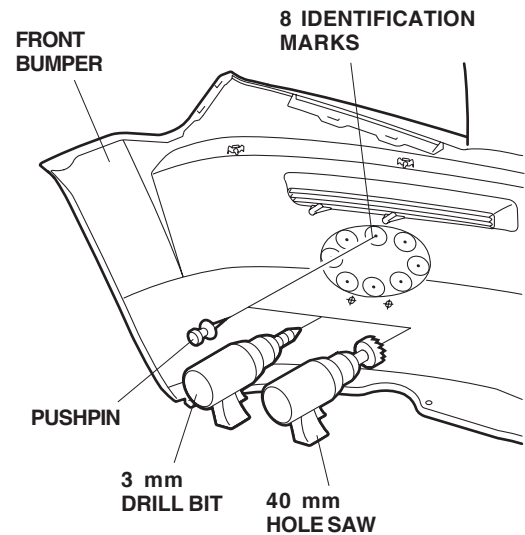

5. While wearing eye protection, drill eight 40 mm holes through each mark on the front bumper. First drill with a 3 mm bit, then finish with a 40 mm hole saw.
6. Using a hacksaw blade, cut out the front bumper along the line between the holes. Remove any burrs from the edge of the hole with a file.

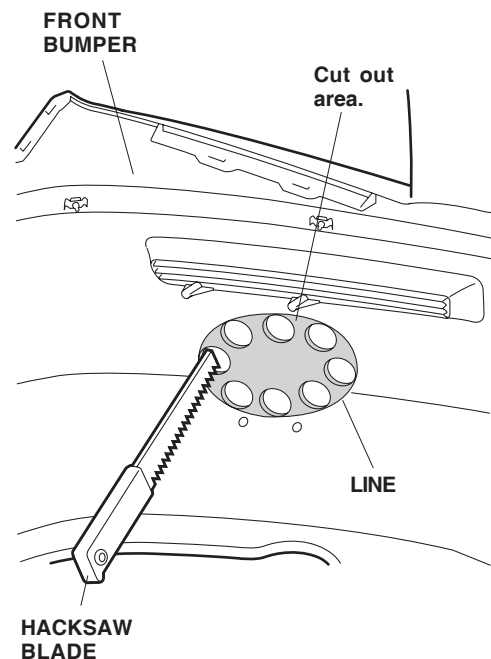

- Using a pushpin, mark the front bumper at each of the two marks below the fog light opening. While wearing eye protection, drill one 5.5 mm hole through each mark. First drill with a 3 mm drill bit, then finish with a 5.5 mm drill bit. Remove any burrs from the edge of the holes.

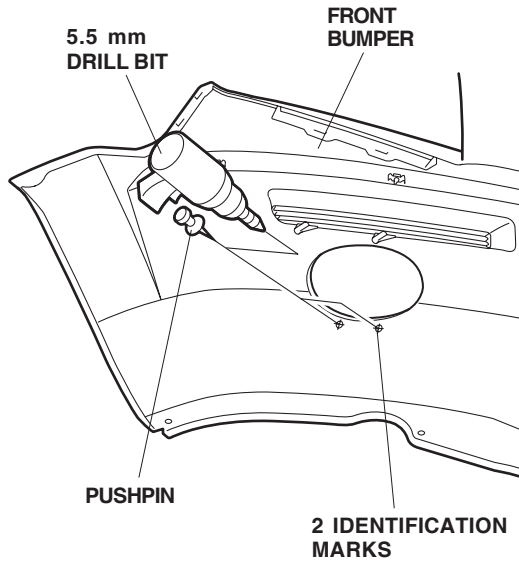

- Repeat steps 4 thru 7 to cut and drill the right side of the bumper.

### Installing the Fog Light

- Install one screw grommet into each square hole in the left fog light bracket.

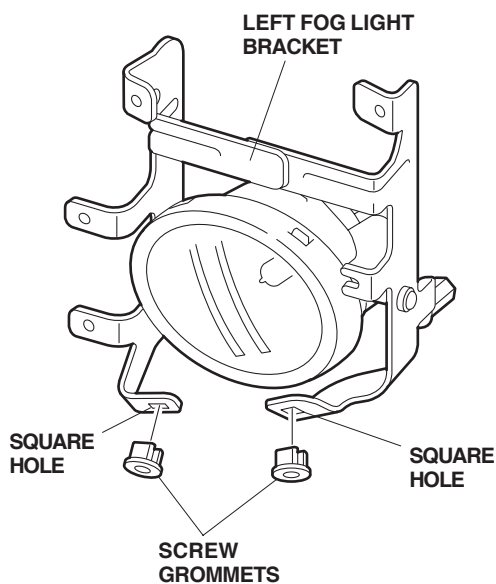

- Attach the left fog light to the front bumper with two 5 x 16 mm self-tapping screws and two 5 x 12 mm self tapping screws (black).

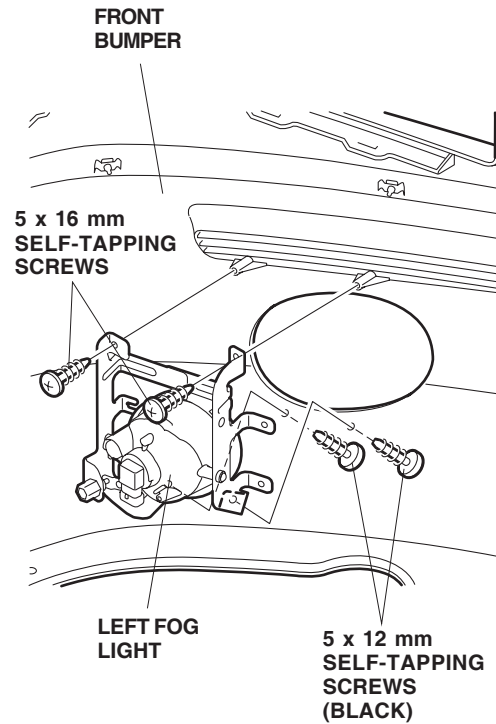

- Attach the left trim to the front bumper with three 5 x 16 mm self-tapping screws.

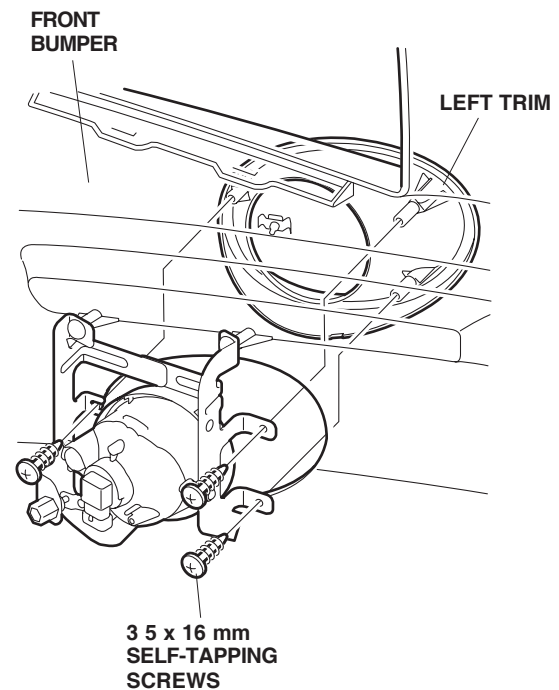

- Repeat steps 9 thru 11 to install the right fog light and right trim.

## Routing the Fog Light Harness

13. Remove the one clip that fastens the washer reservoir tank.

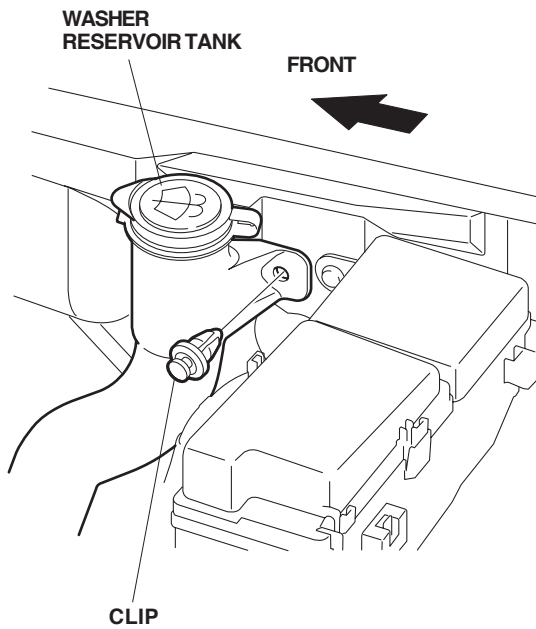

14. Remove the bolt that fastens the relay box, and release the two retaining tabs. Remove the relay box.

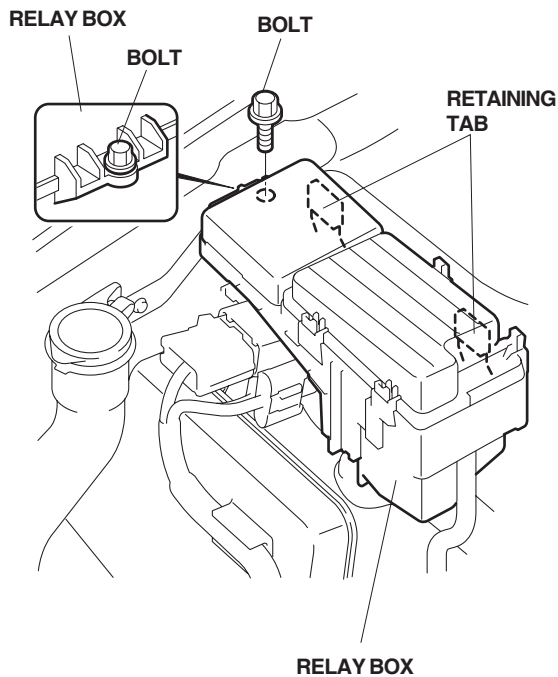

15. Release the four retaining tabs, and remove the under-hood fuse/relay box upper cover.

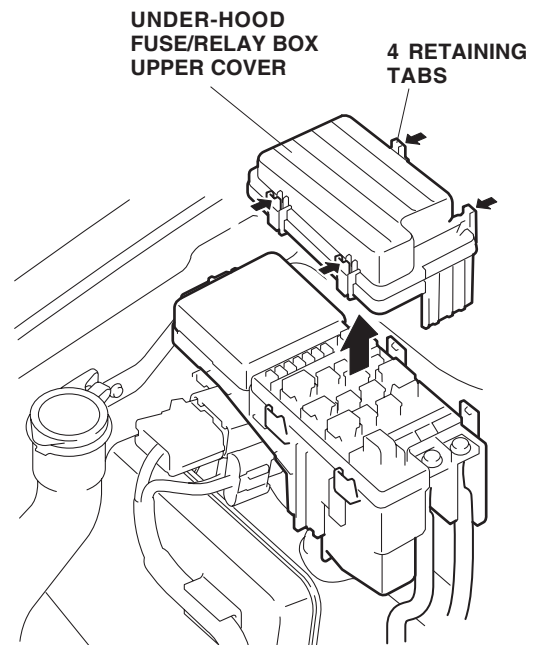

16. Using masking tape, mark the square terminal. Remove the two terminals (one bolt for each). The masking tape functions as an installation mark. Note where each terminal attaches.

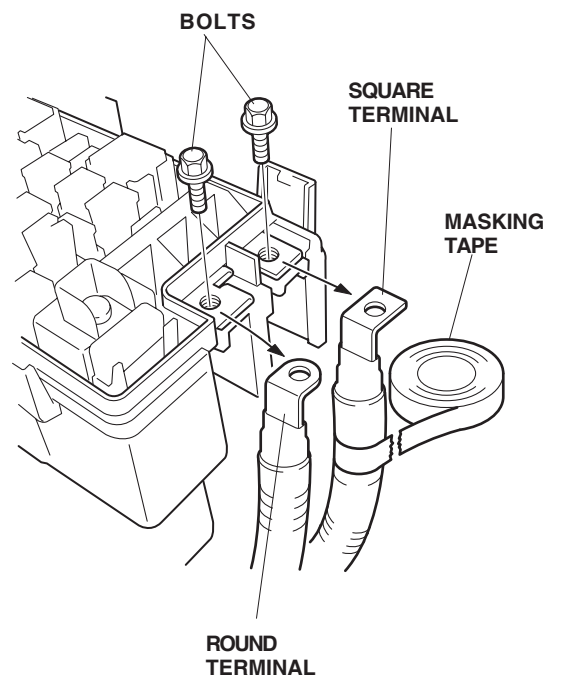

17. Release the six retaining tabs, and remove the under-hood fuse/relay box lower cover.

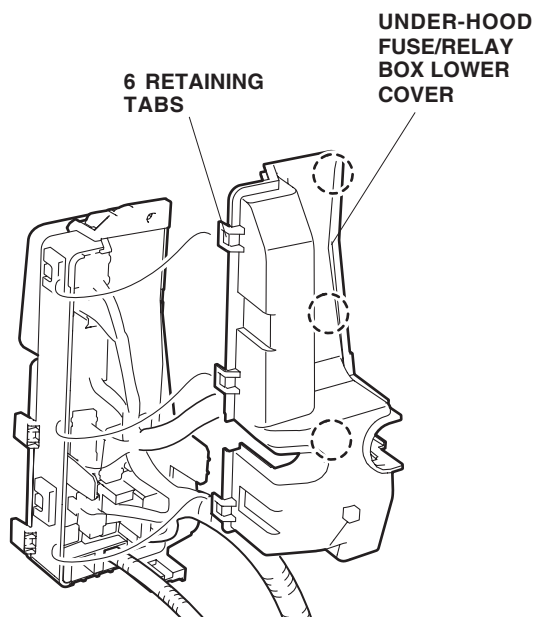

18. Remove the coolant overflow bottle from the bracket and set it aside. Route the white terminal from the fog light harness under the right headlight and into the engine compartment. Route the fog light harness 4-pin connector along the front bulkhead.

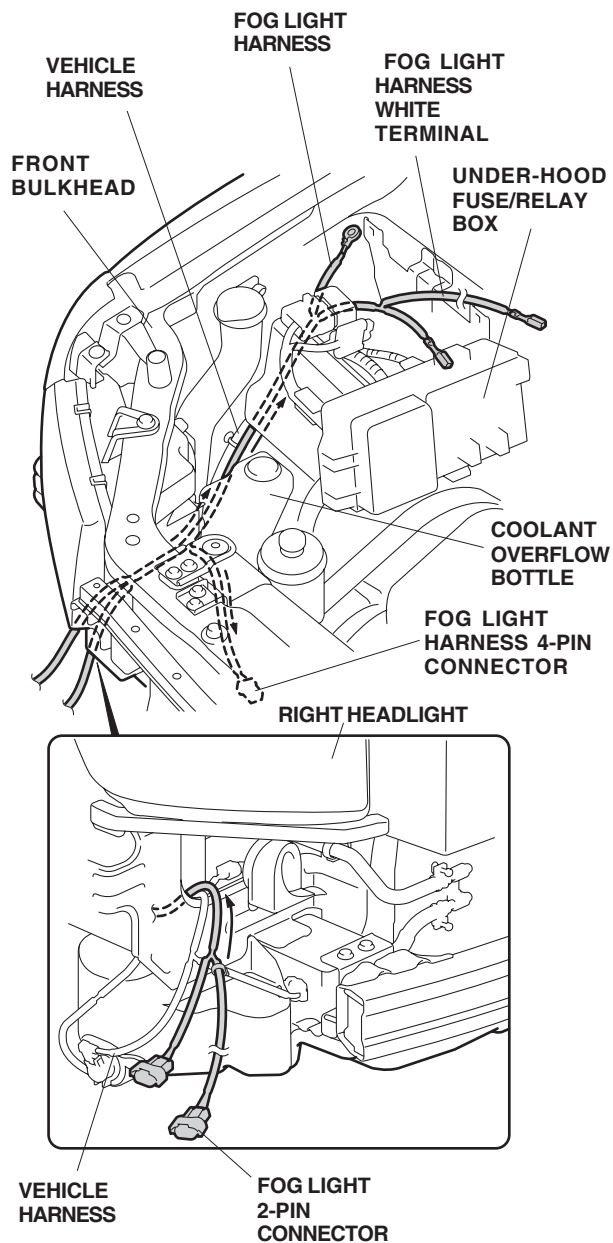

19. Route the white terminal from the fog light harness along the vehicle harness to the under-hood fuse/relay box.

20. On the bottom of the under-hood fuse/relay box, unplug the vehicle 18-pin connector. Release the lock on the vehicle 18-pin connector, and push the fog light harness red/green terminal into the vehicle 18-pin connector. Secure the lock on the 18-pin connector.

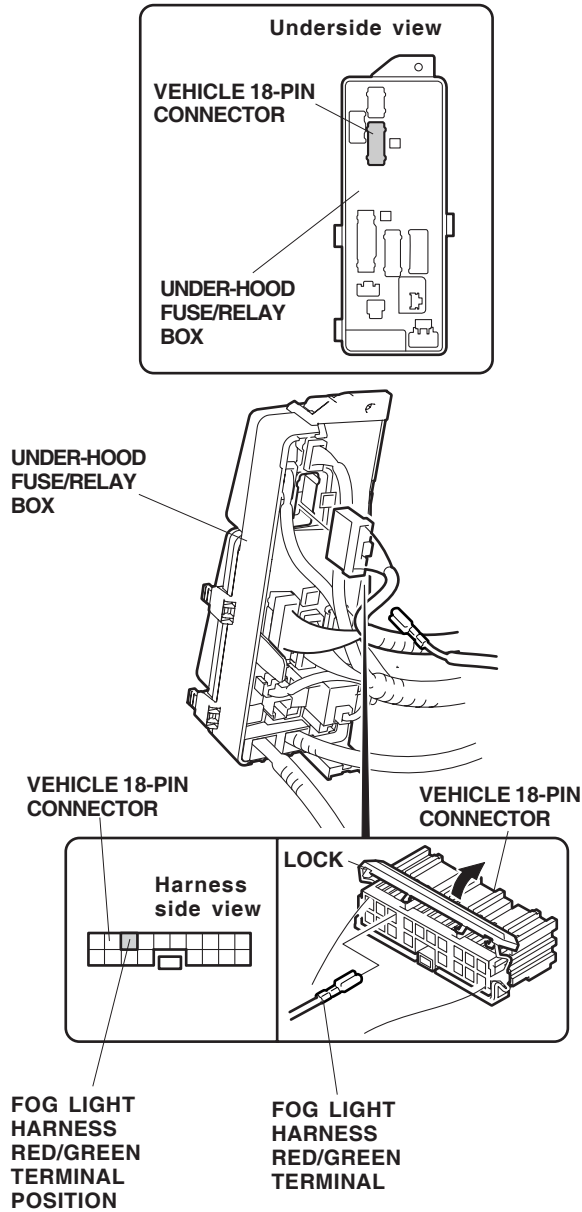

21. Reconnect the vehicle 18-pin connector into the under-hood fuse/relay box.

22. Secure the fog light harness to the vehicle harness with one small wire tie.

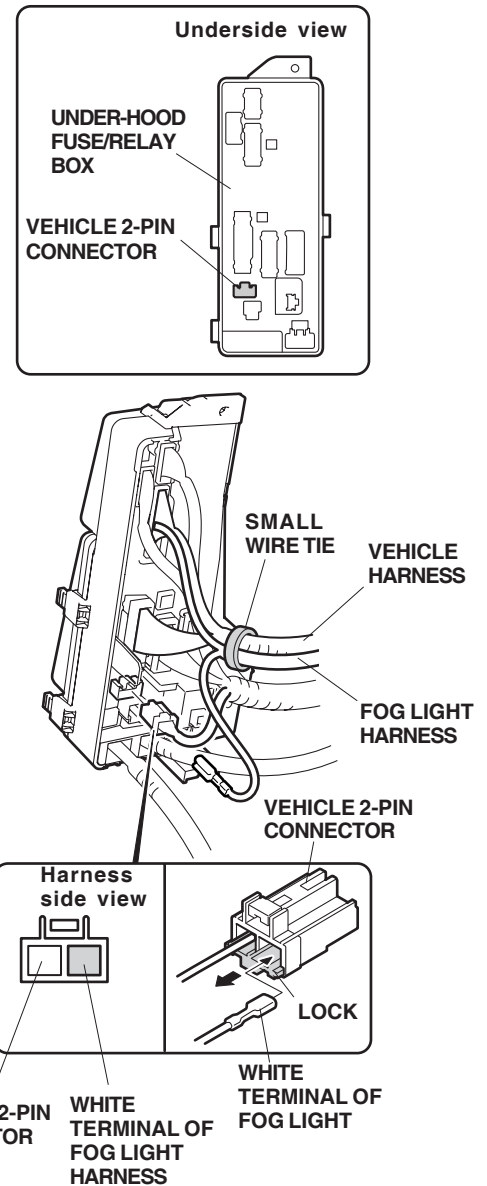

23. Unplug the vehicle 2-pin connector. Release the lock on the vehicle 2-pin connector, and push the fog light harness white terminal into the vehicle 2-pin connector. Reconnect the lock on the 2-pin connector, and plug the vehicle 2-pin connector into the under-hood fuse/relay box.

24. Remove and discard the vehicle bolt that fastens the vehicle bracket, and attach the fog light harness ground terminal with the new ground bolt.

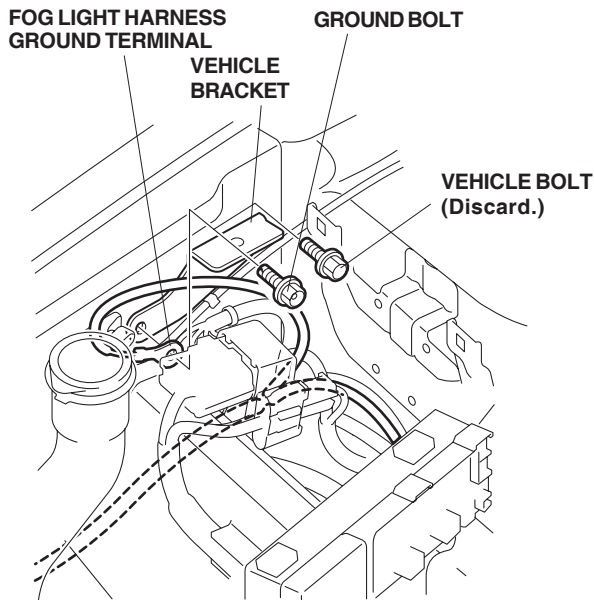

25. Secure the fog light harness to the vehicle harness with five wire ties.

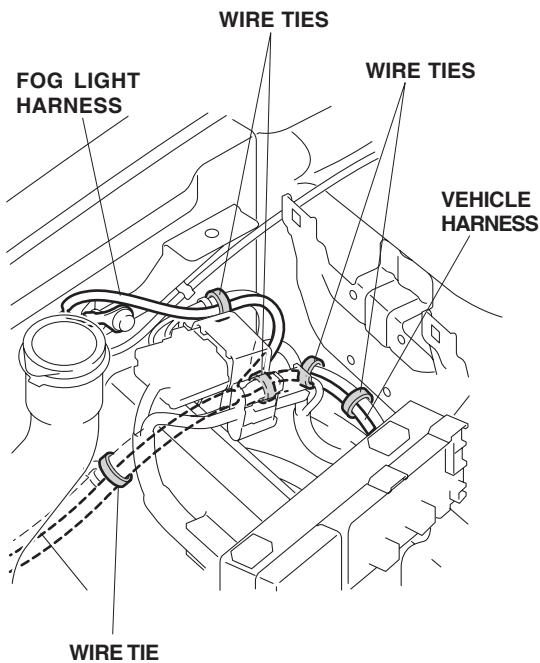

26. Reinstall the under-hood fuse/relay box lower cover, and reinstall the vehicle terminals to the relay box as shown. Be sure the square and round terminals are in their original positions. Remove the masking tape.

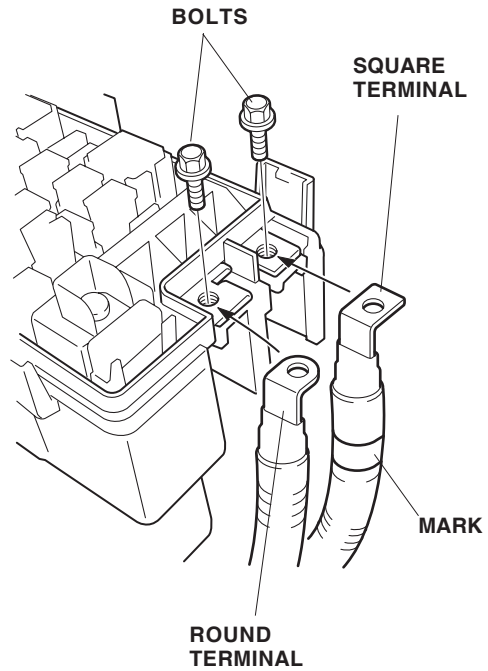

27. Insert the 20A fuse block into the under-hood fuse/relay box.

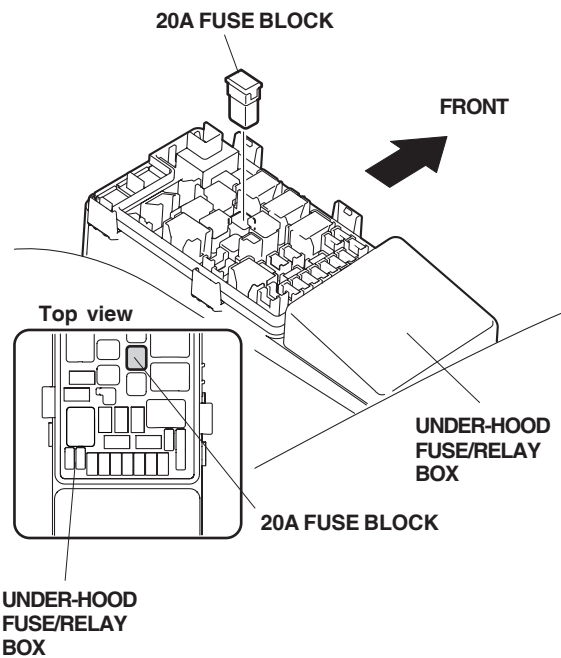



28. Attach the 20A fuse label onto the inside of the under-hood fuse/relay box upper cover.

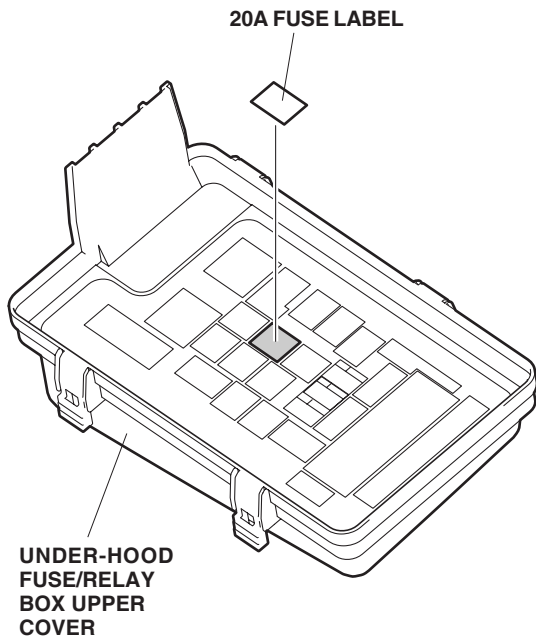

29. Reinstall the under-hood fuse/relay box upper cover.
30. Behind the right headlight, locate the 2-pin connector blue taped to the vehicle harness, and remove the blue tape to free the connector. Plug the fog light harness 2-pin connector into the vehicle 2-pin connector.

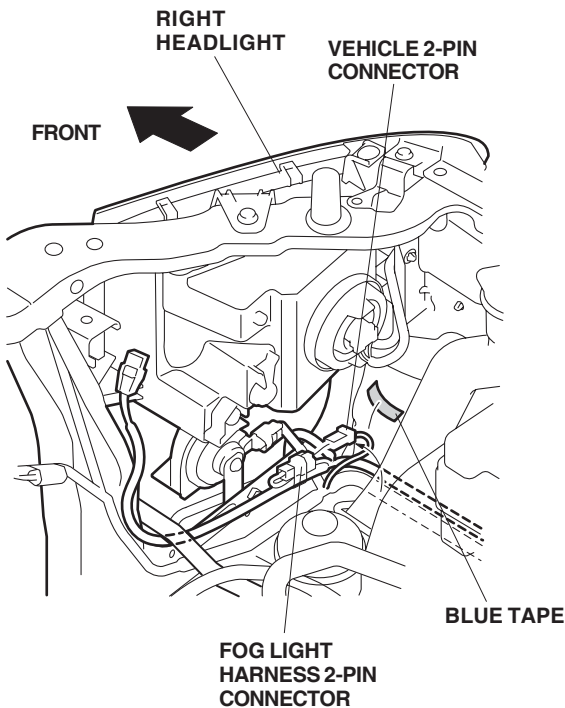

31. Install the relay bracket to the relay with one 6 x 12 mm washer-bolt and one flange nut.

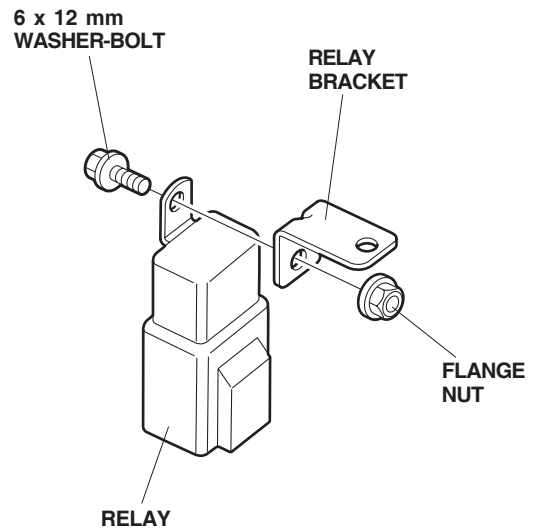

32. Attach the relay bracket to the vehicle frame with one 6 x 12 mm washer-bolt and one flange nut.

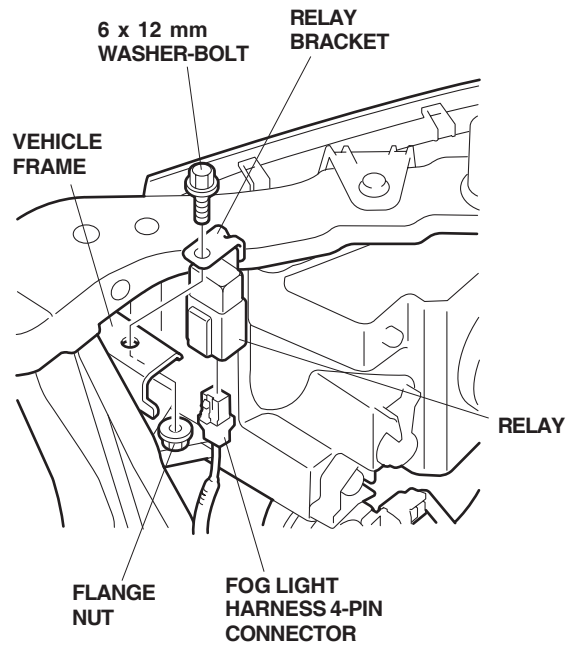

33. Plug the fog light harness 4-pin connector into the relay.

34. Secure the fog light harness to the vehicle harness with four wire ties.

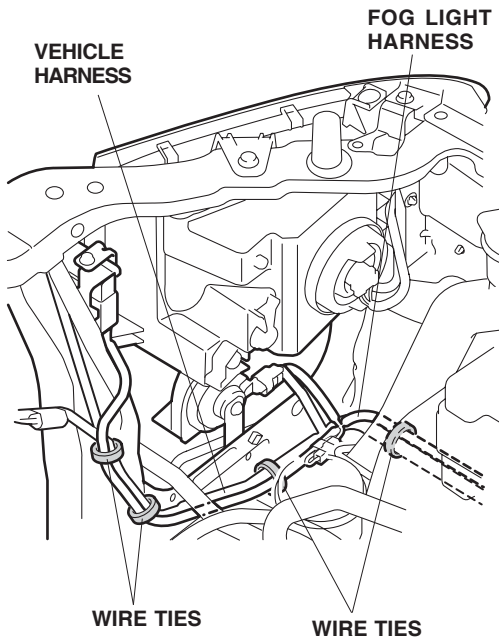

35. Secure the fog light harness to the vehicle harness with one wire tie. Secure the fog light harness to the right end of the bumper beam with one black wire tie with clip at the green tape.

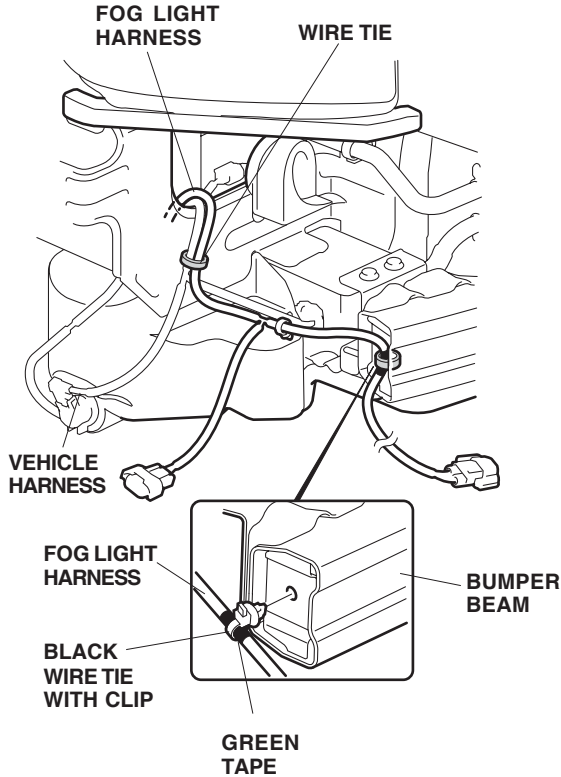

36. Secure the fog light harness to the bumper beam:

*With vehicle harness:*

- Route the fog light harness along the bumper beam, and secure it to the vehicle harness and bumper beam with three wire ties, two white wire ties with clips, and one black wire tie with clip.

*Without vehicle harness:*

- Route the fog light harness along the bumper beam, and secure it to the bumper beam with four white wire ties and one black wire tie.

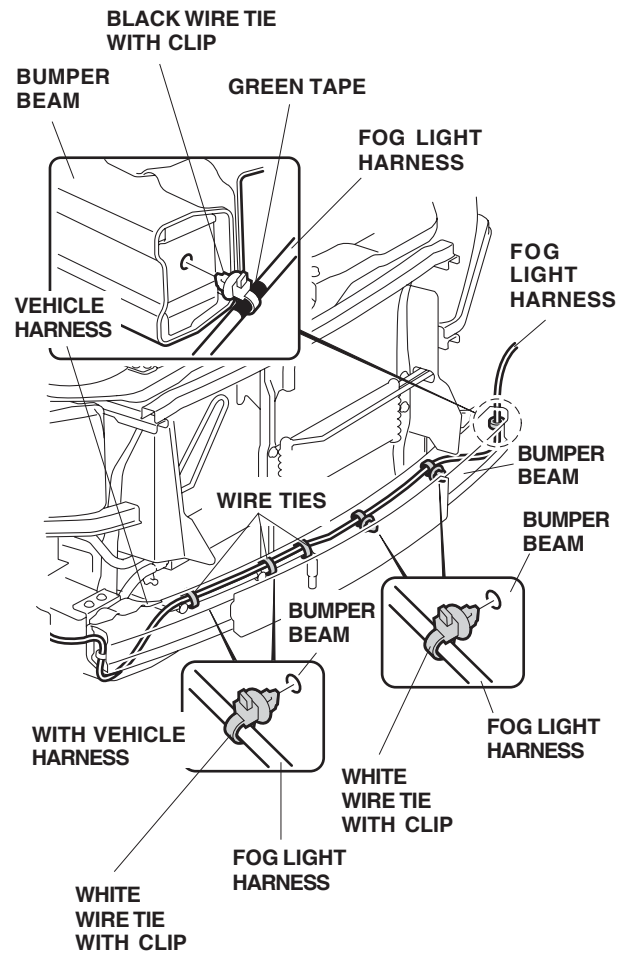

37. With an assistant holding the bumper near the vehicle, plug the fog light harness 2-pin connectors into the right and left fog light, and push the clip on the fog light harness into the hole of the right and left fog light bracket.

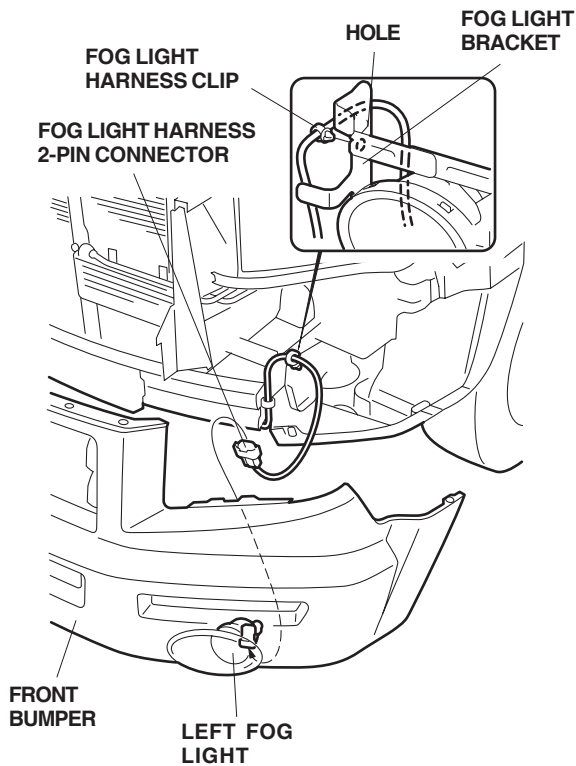

38. Reinstall the one clip, two bolts and two self-tapping screws to secure the front bumper. Do not install the four outboard bolts to the front bumper at this time.

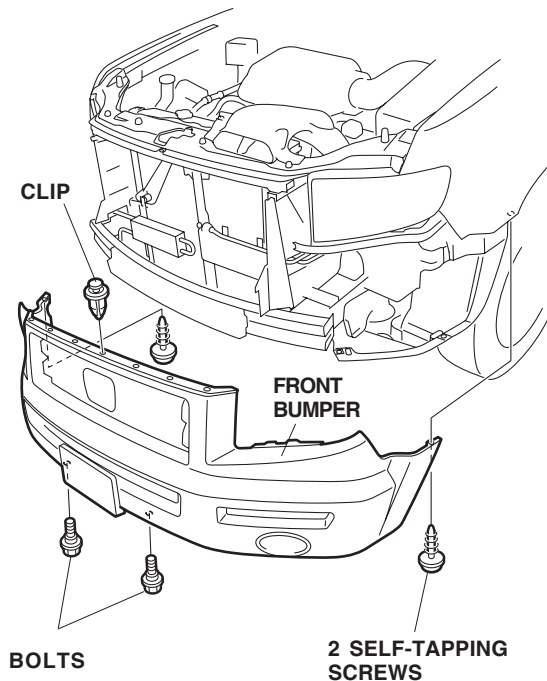

## Routing the Switch Harness

39. Remove the left dashboard side cover (seven clips).

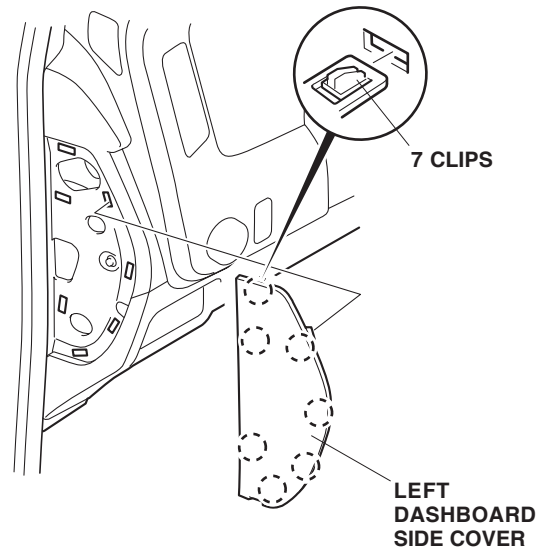

40. Remove the driver's dashboard lower cover:

- Remove the one self-tapping screw.
- Release the nine clips, and pull out the driver's dashboard lower cover.
- Unplug the vehicle connectors and, if equipped, remove the air tube and unplug the in-car temperature sensor connector. Remove the lower cover.

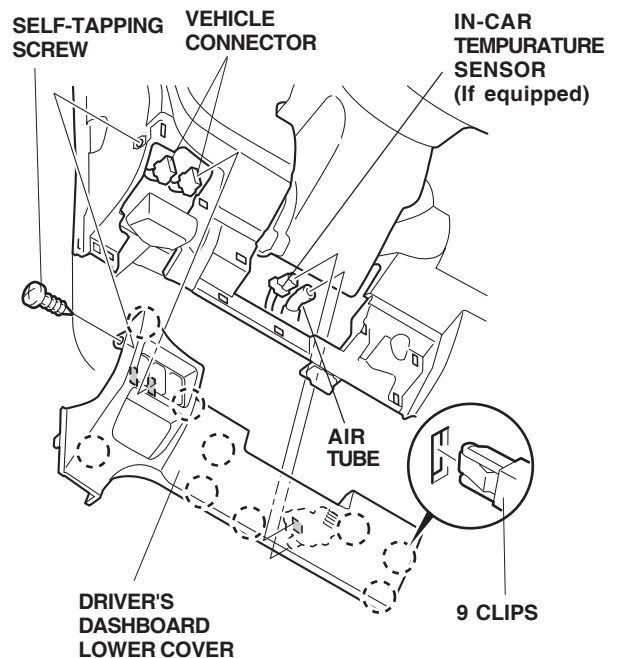

41. Remove the switch lid from the driver's dashboard lower cover, and install the fog light switch into the driver's dashboard lower cover.

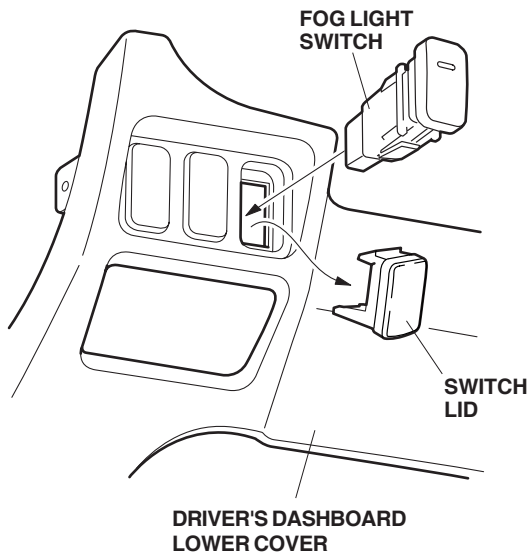

42. On the front of the fuse box, locate the 3-pin connector (brown), and unplug it. Release the connector lock, and push the blue terminal and yellow/red terminal from the switch harness into the vehicle 2-pin connector. Reattach the connector lock.

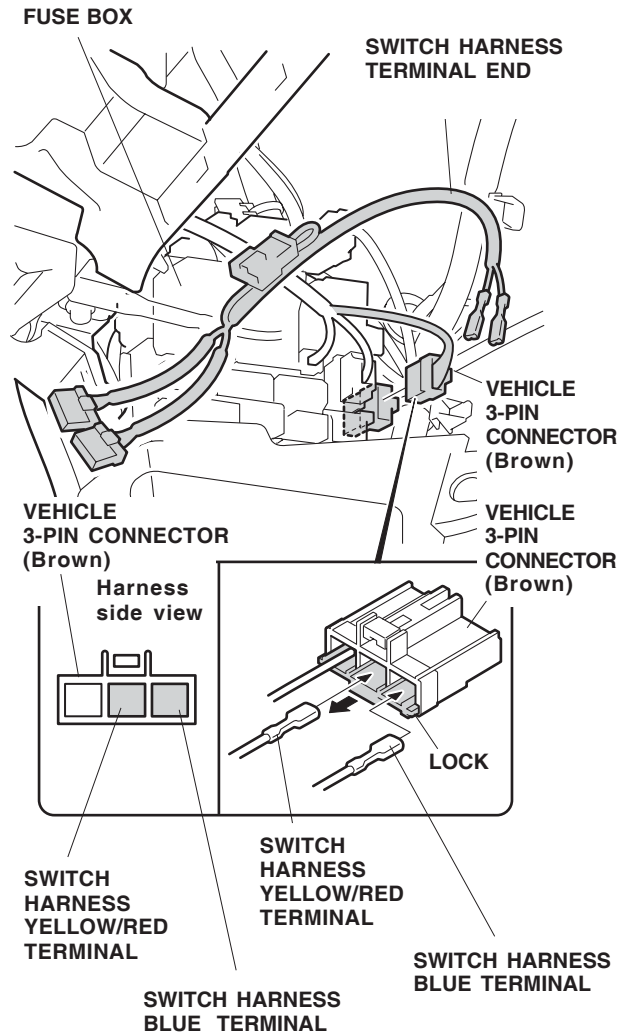

43. Reconnect the vehicle 3-pin connector to the fuse box.

44. Route the two switch harness 5-pin connectors up to the opening in the dashboard where the cruise control switch and the VSA switch were disconnected.

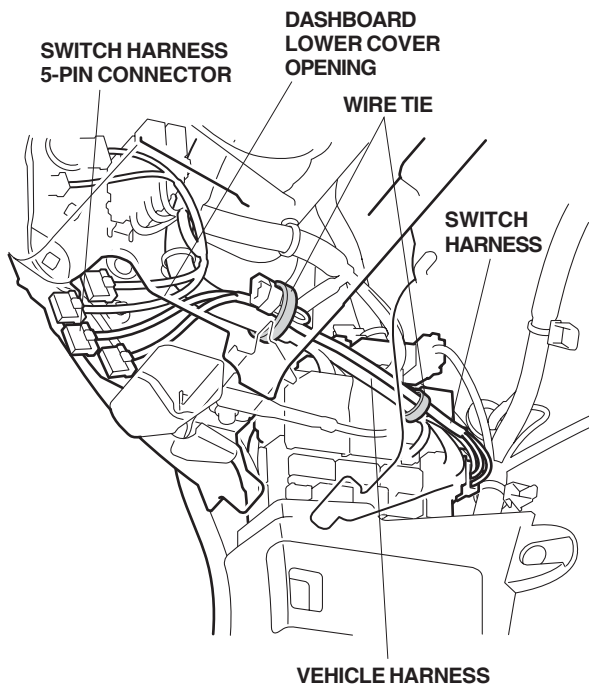

45. Secure the switch harness to the vehicle harness with two wire ties.
46. Route the vehicle cruise control 5-pin connector (blue) down, and plug it into the switch harness 5-pin connector (blue).

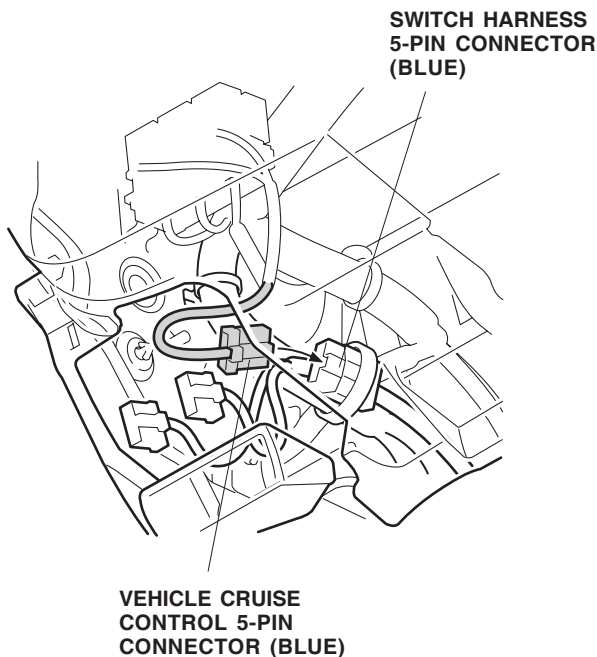

47. Reinstall the driver's dashboard lower cover:

- Plug the VSA 5-pin connector (grey) into the VSA switch.
- Plug the switch harness 5-pin connector (blue) into the cruise control switch, and plug the other switch harness 5-pin connector (brown) into the fog light switch.
- If equipped, reattach the air tube, and plug in the in-car temperature sensor connector, then reinstall the driver's dashboard lower cover.

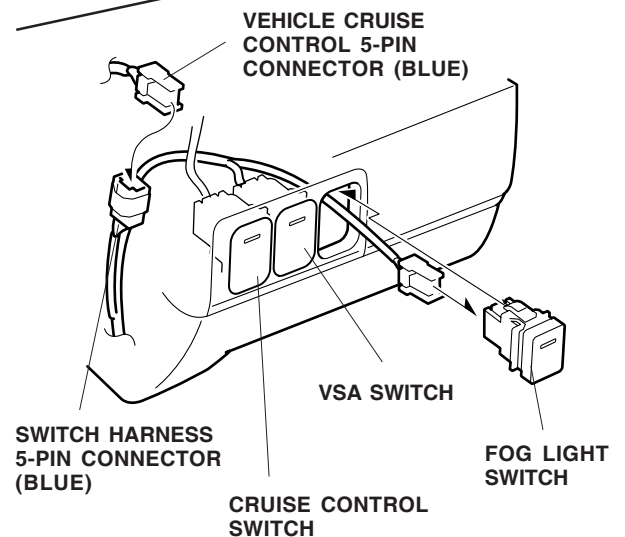
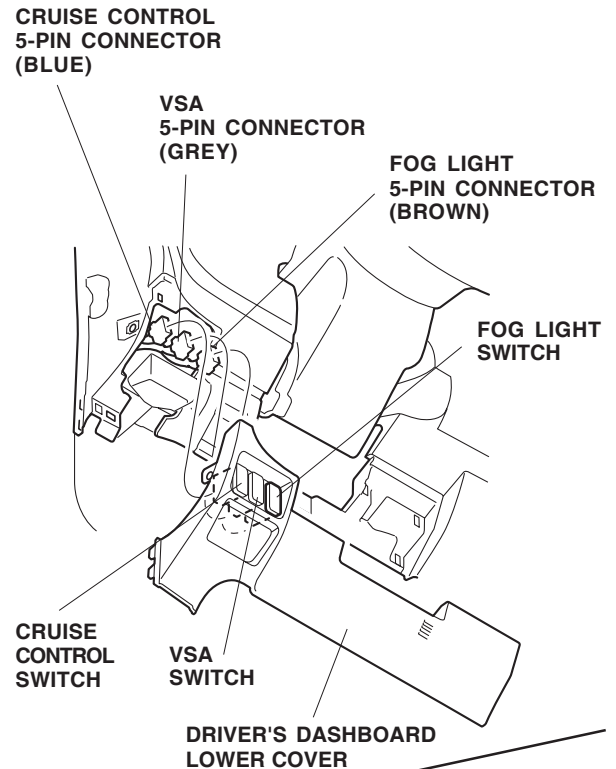

48. Check that all wire harnesses are routed properly and all connectors are plugged in.
49. Reinstall all removed parts. Do not reinstall the outboard bumper bolt at this time. Check that all clips and fasteners are installed securely.
50. Reconnect the negative cable to the battery.

## USE AND CARE

### How to Operate Fog Lights

- Turn the light switch to the “on” position (headlights on low beam ).
- Press the fog light switch (indicator is on).

The fog light lenses can cloud when the outside temperature is cold; this is normal and should go away in warm weather.

### Fog Light Aiming Adjustment

51. Adjust the fog light:
  - Pull down the inner fender.
  - Adjust the aiming according to local laws and regulations.
  - To adjust, turn the aiming adjustment knob in or out until the correct aiming is obtained.

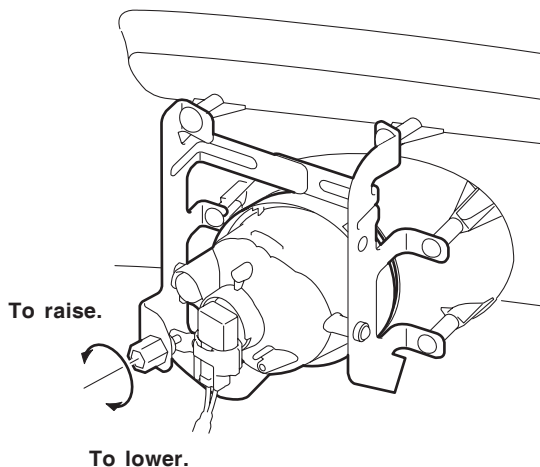

52. Reset the clock, and reset the radio station presets.
  53. Reinstall the four outboard bumper bolts.
- NOTE: Whenever the battery is disconnected, the driver’s AUTO function is disabled.
54. Start the engine. Push down on the driver’s window switch until the window is fully open.

55. Pull up on the driver’s window switch fully to close the window completely, then hold the switch for 2 seconds or more.
56. Test the window AUTO function.

## BULB REPLACEMENT

1. Remove the two bolts from the bottom of the front bumper, and pull down the inner fender.

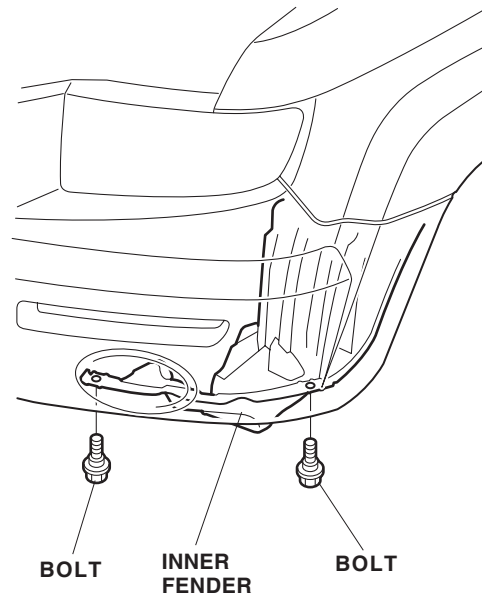

2. Unplug the connector from the fog light.
3. Remove the bulb.

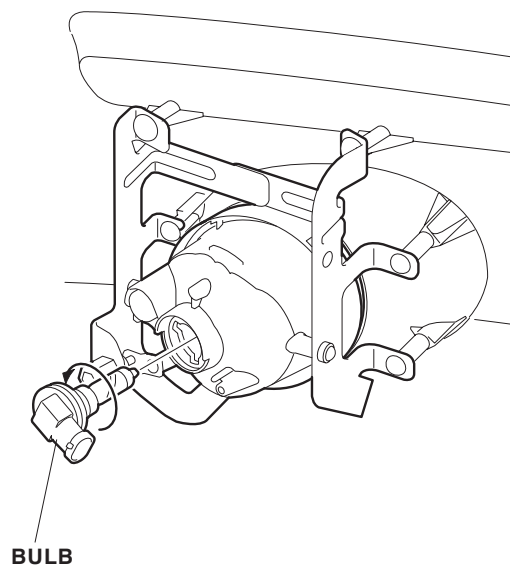

4. Install the new bulb into the fog light.
  - Use only a genuine Honda halogen light bulb of specified wattage.

Rating: 12V 55W H11 Halogen Light Bulb  
P/N: 33165-S5A-003

- Do not touch the bulb. Oily or greasy substances on the bulb can shorten its service life due to the heat produced when the bulb is turned on. If the bulb is accidentally touched, wipe it clean with a soft cloth that has been dampened with a denatured alcohol or a mild detergent solution.
- Align the tab on the fog light with the cutout in the bulb when installing the new bulb. If not aligned, the fog light may annoy oncoming drivers.

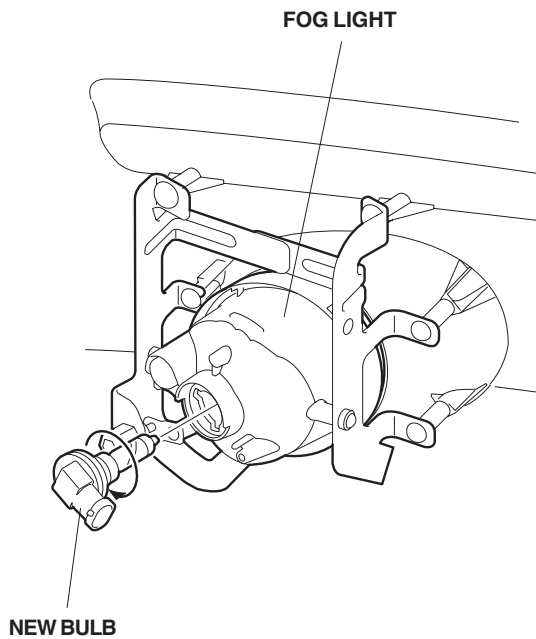

5. Reinstall the removed parts in the reverse order of removal.
  - Check that the wire harnesses are not pinched.
  - Be sure to tighten the self-tapping screw and bolts securely.
6. Check the operation of the fog light; adjust the aiming if necessary.

# CIRCUIT DIAGRAM

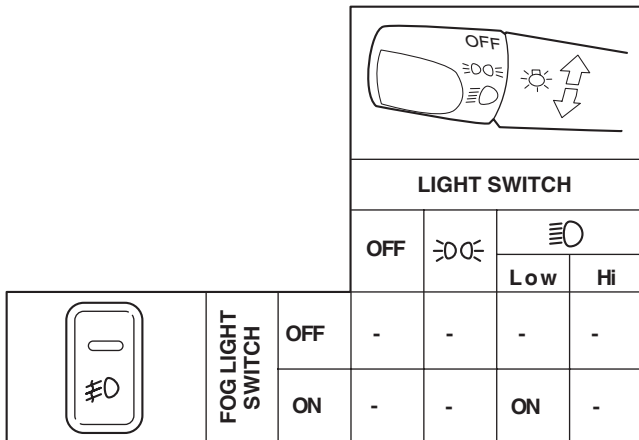
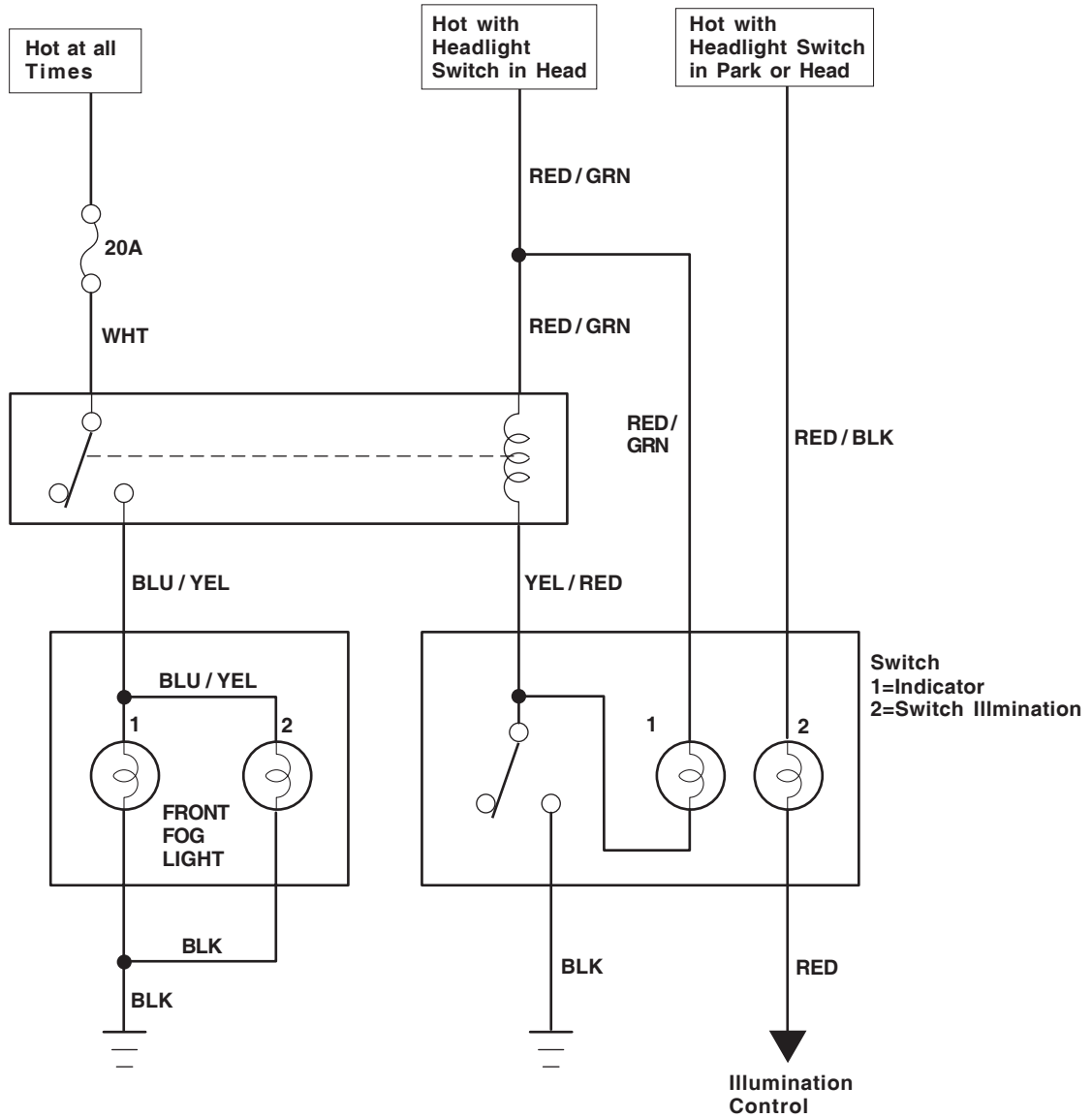

BLK	BLACK	BRN	BROWN
YEL	YELLOW	ORN	ORANGE
BLU	BLUE	PUR	PURPLE
GRN	GREEN	NAT	NATURAL
RED	RED	PNK	PINK
WHT	WHITE	GRY	GRAY
LT BLU	LIGHT BLUE	LT GRN	LIGHT GREEN